

Powerful Security, with 8 IPsec VPN Tunnels for Secure Remote Access



Want strong security at a small price? NETGEAR's ProSafe VPN Firewall 8 FVS114 provides business class protection. Stateful packet inspection (SPI) stops major denial-of-service (DoS) attacks. Intrusion Detection alerts you to hackers and attacks. Up to 8 simultaneous virtual private network (VPN) connections protect links between business locations, encrypting all traffic as it traverses the Internet—perfect for telecommuters and remote offices. With 4 10/100 Mbps auto-sensing, Auto Uplink™ switched LAN ports and Network Address Translation (NAT) routing, up to 253 users can access your broadband connection at the same time.

**Trusted Security**

More than just a NAT router, the ProSafe VPN Firewall 8 FVS114 provides a true SPI firewall, protecting you from DoS attacks such as ping of death, SYN flood, LAND attacks, IP spoofing, tear drop, and many more. Up to 8 IPsec VPN connections can be initiated automatically—perfect for connecting telecommuters and road warriors into the home office. DES, 3DES, or 256-bit AES encryption secures remote access and keyword content filtering allows you to control Web access and block unacceptable sites. Logging, reporting, and real-time notification alert you to problems or attacks.

**Full Feature Set**

As a part of a family of business-class firewalls, the ProSafe FVS114 is a complete SMB solution. Four integrated 10/100 Mbps LAN ports offer LAN connectivity to PCs and servers, or to Fast Ethernet switches and wireless access points. 10/100 Mbps WAN port is ready for new, higher-speed broadband capabilities. It even comes with an Ethernet cable (up to \$10 value).

**Superior Value and Usability**

Smart Wizard™ connects to your ISP quickly, and the easy-to-use Web-based configuration screen and Install Assistant reduce setup time. The VPN Wizard capability makes setting up secure, remote connections a breeze. The ProSafe FVS114 is VPNC compliant and is compatible with all major VPNC certified devices, including those from Cisco®, Juniper®/Netscreen, Checkpoint®, and supports standards-based IPsec VPN Client software including NETGEAR's ProSafe VPN Client Software (VPN01L/05L) and Safenet VPN clients. Support for DHCP (client and server) as well as PPPoE allows for easy, widespread deployment. Auto Uplink™ on the LAN ports eliminates the need for crossover cables. Compatible with Windows®, Macintosh®, UNIX®, and Linux®, or any other TCP/IP based platforms.

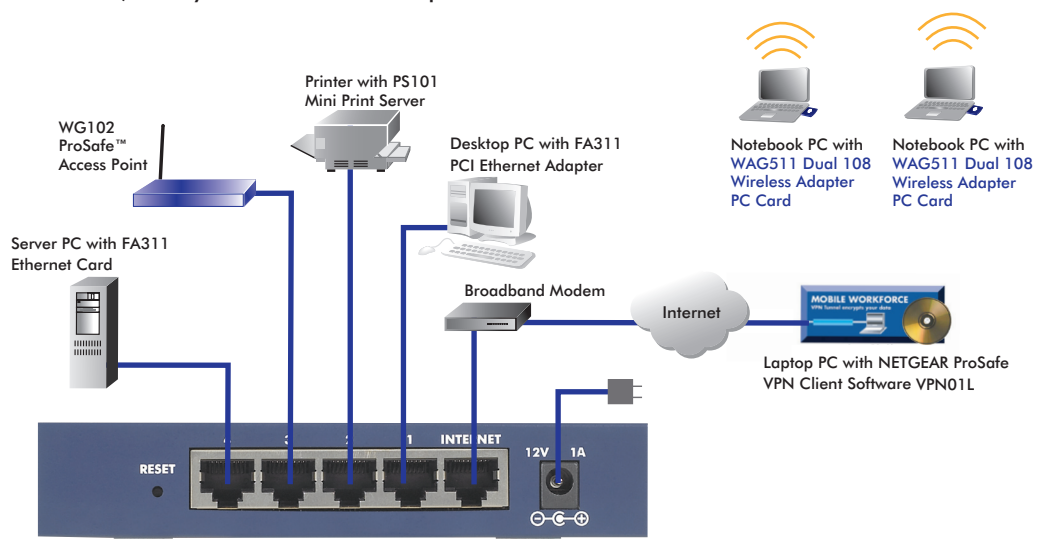

## Technical Specifications

### • Physical Interfaces

- LAN ports: Four (4) 10/100 Mbps auto-sensing, Auto Uplink™, RJ-45 ports
- WAN port: 10/100BASE-T Ethernet RJ-45 port to connect to any broadband modem, such as DSL or cable

### • Security Features

- SPI firewall: Stateful packet inspection (SPI) to prevent notorious denial-of-service (DoS) attacks, intrusion detection system (IDS) including logging, reporting and e-mail alerts, address, service and protocol, Web URL keyword filtering, prevent replay attack (reassembly attack), port/service blocking. Advanced features include block Java/URL/ActiveX based on extension, FTP/SMTP/RPC program filtering.
- VPN functionality: Eight (8) dedicated VPN tunnels, Manual Key and Internet Key Exchange Security Association (IKE SA) assignment with pre-shared key and RSA/DSA signatures, key life and IKE lifetime time settings, perfect forward secrecy (Diffie-Hellman groups 1 and 2 and Oakley support), operating modes (main, aggressive, quick), fully qualified domain name (FQDN) support for dynamic IP address VPN connections.
- IPsec support: IPsec-based 56-bit (DES), 168-bit (3DES), or 256-bit (AES) encryption algorithm, MD5 or SHA-1 hashing algorithm, AH/AH-ESP support, PKI features with X.509 v.3 certificate support, remote access VPN (client-to-site), site-to-site VPN, IPsec NAT traversal (VPN pass-through).
- Mode of operation: One-to-one/multi-to-one Multi-Network Address Translation (NAT), classical routing, unrestricted users per port.
- IP address assignment: Static IP address assignment, internal DHCP server on LAN, DHCP client on WAN, PPPoE client support.

### • Performance Features

- Throughput: Up to 11.5 Mbps WAN-to-LAN, up to 2.1 Mbps for 3DES throughput

### • Management Features

- Administration interface: Web graphic user interface, Secure Sockets Layer (SSL) remote management, user name and password protected; secure remote management support authenticated through IP address or IP address range and password; configuration changes/upgrades through web GUI.
- Configuration and upgrades: Upload and down load configuration settings, firmware upgradeable flash memory
- Logging: SYSLOG, email alerts

### • Functions

- VPN Wizard to simplify configuration of the VPN, Smart Wizard to automatically detect ISP address type (static, dynamic, PPPoE), port range forwarding, port triggering, exposed host (DMZ), enable/disable WAN ping, DNS proxy, MAC address cloning/spoofing, Network Time Protocol NTP support, keyword content filtering, email alerts, DHCP server (info and display table), PPPoE login client support, WAN DHCP client, diagnostic tools (ping, trace route, other), port/service, Auto-Uplink on switch ports

### • Protocol Support

- Network: IP routing, TCP/IP, UDP, ICMP, PPPoE, , UPnP
- IP addressing: DHCP (client and server)
- Routing: RIPv1, RIPv2 (static routing, dynamic routing)
- VPN/security: IPsec (ESP, AH), MD5, SHA-1, DES, 3DES, IKE, PKI, AES

### • User Support

- LAN: Up to 253 users

### • Maintenance

- Save/restore configuration, Restore Defaults, Upgrades via Web Browser, Display Statistics, Logging, SYSLOG support.

### • Hardware Specifications

- Processor: 200 MHz 32-bit RISC
- Memory: 2 MB flash, 16 MB SDRAM
- Power requirements: 100-240V AC, 50-60 Hz, 12V 1.0 A Max. or @230V, 0.06 A Max.
- Power adapter: 12V DC, 1.0A plug is localized to country of sale

### • Physical Specifications

- Dimensions: (w x d x h)  
14.06 x 9.95 x 2.66 cm  
(5.54 x 3.92 x 1.05 in.)
- Weight: .368 kg (.81 lb)

### • Environmental Specifications

- Operating temperature: 0° to 40° C (32° to 104° F)
- Operating humidity: 90% maximum relative humidity, non-condensing

### Warranty

- Firewall: NETGEAR Lifetime Warranty†
- Power adapter: NETGEAR 3-year Warranty

### ProSupport™ Service Packs Available

#### • On Call 24 x 7

- PMB0331-100 (US)
- PMB0331 (non-US)

#### • Xpress HW

- PRR0331

### System Requirements

- Cable, DSL, satellite or wireless broadband modem and Internet service
- Ethernet connectivity from broadband modem
- Network card for each connected PC
- Network software (e.g. Windows®)
- Internet Explorer 5.0 or higher or Netscape Navigator 7.2 or higher

### Package Contents

- ProSafe VPN Firewall 8 (FVS114)
- Power adapter
- Ethernet cable
- Installation guide
- Resource CD
- Warranty/support information card

### NETGEAR Related Products

- ProSafe VPN Client Software (VPN01L and VPN05L)

### Ordering Information

- North America: FVS114NA
- Europe - General: FVS114IS
- Europe - German: FVS114GR
- Europe - UK: FVS114UK
- Asia: FVS114AU

# NETGEAR®

4500 Great America Parkway  
Santa Clara, CA 95054 USA  
1-888-NETGEAR (638-4327)  
E-mail: [info@NETGEAR.com](mailto:info@NETGEAR.com)  
[www.NETGEAR.com](http://www.NETGEAR.com)

©2007 NETGEAR, Inc., the NETGEAR logo, Connect with Innovation, Everybody's connecting, FrontView, the Gear Guy logo, IntelliFi, ProSafe, RangeMax, ReadyNAS, RAIDar, RAIDiator, X-RAID, and Smart Wizard are trademarks of NETGEAR, Inc. and/or its subsidiaries in the United States and/or other countries. Microsoft and Windows are trademarks of Microsoft Corporation in the United States and/or other countries. Other brand and product names are trademarks or registered trademarks of their respective holders. Information is subject to change without notice. All rights reserved.

\*Free basic installation support provided for 90 days from date of purchase. Advanced product features and configurations are not included in free basic installation support; optional premium support available.

†Lifetime warranty for product purchased after 05/01/2007. For product purchased before 05/01/2007, warranty is 3 years.